



RUGGED DISC BRAKE SOLUTIONS.

For enhanced control and safety on
draw-works, hoists, winches, propeller
shafts and other industrial machinery.

KOBELT
Putting you in control.

KOBELT

DISC BRAKES



SHIP LOADING - Kobelt brakes' bronze construction is well suited for corrosive environments.



MINING - Kobelt brakes meet the rigorous demands on material handling equipment.



OIL & GAS - Kobelt brakes are used for emergency/holding and tensioning applications for draw-works, plus off-shore oil equipment.



MARINE - Kobelt brakes excel in harsh maritime conditions for pleasure craft and working boats.

For over three decades, Kobelt has been manufacturing rugged, durable disc brakes for the oil and gas, mining, manufacturing and maritime industries. Built using bronze and stainless steel, Kobelt brakes provide solid, reliable control for draw-works, hoists and winches, as well as propeller shaft brakes for marine vessels and other applications. Kobelt's line of air and hydraulic actuated brake systems accommodate a broad range of torque requirements and are configurable to customer specifications.

Kobelt spring applied brakes provide safety and support for holding or emergency braking applications. Kobelt air applied service brakes, with their accurate proportional control over the respective load, are well suited for speed control and tensioning applications. Kobelt also manufactures brakes which integrate both functions, emergency braking and tensioning, into a single brake system.

Our in-house bronze die casting ensures that Kobelt brakes are well suited for use in harsh, corrosive environments. Furthermore, our broad range of sizes and configurations ensures that there is a solution for your specific application. From an operational perspective, components subject to wear are easily accessible for adjustment or replacement in order to minimize downtime and lower maintenance costs. Kobelt's vertically integrated factory enables industry-leading fulfillment times whether for standard products or custom alterations to fit specific requirements.

Brake Solutions

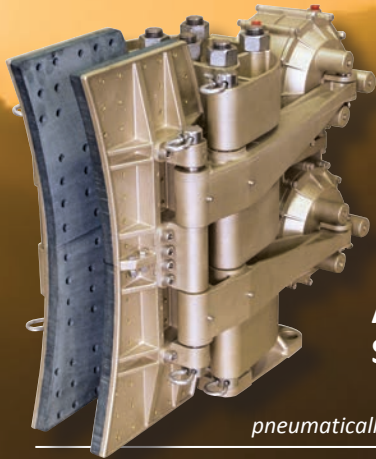

Air Applied Service Brakes

pneumatically applied for tensioning

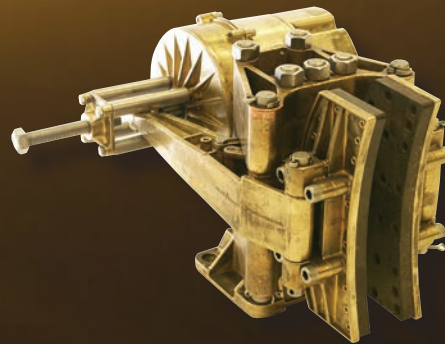

Spring Applied Emergency Brakes

loss of pressure actuates "fail safe" emergency braking

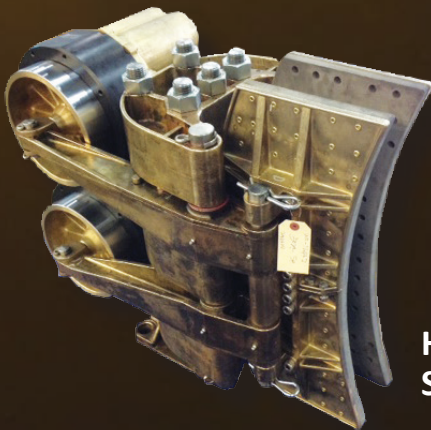

Hydraulic Applied Service Brakes

high pressure brake actuators

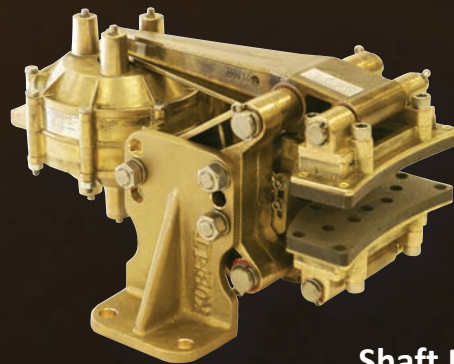

Shaft Brakes

smaller disc sizes and brakes to assist in propellor control and lower wear on engines and clutches

We offer custom brake solutions built to OEM specifications with short lead times.

Key Features

- Quality bronze & stainless steel construction for durability and reliability
- Wear affected components are accessible for ease of pad replacement & maintenance
- Air vented discs for efficient heat dissipation
- Vertical or side mount installation configurations
- Air applied calipers utilize diaphragms for accurate control capability

Benefits

- Long-lasting in harsh & corrosive environments for lower cost of ownership
- Industry-leading manufacturing & fulfillment times
- Replacement parts can be installed quickly & efficiently with little downtime
- Wide range of sizes & clamping forces

Caliper Model	Weight		Vented Disc Sizes (thickness x pad width)		Disc Diameter Sizes Available		Approximate Torque*	
	lbs	kg	inches	mm	inches	mm	lbs-ft	N-m
5019	15	7	3/4 x 2	19 x 50	9, 12, 15, 18 & 20	229, 305, 381, 457, 508	680 to 1,740	920 to 2,370
5020	36	16	1-1/4 x 2.5	31.8 x 64	12, 15, 18, 21, 24, 27, 30	305, 381, 457, 533, 686, 700, 762	1,350 to 3,910	1,830 to 5,300
5021	53	24	2 x 4	50 x 102	20, 25, 30, 35, 40, 45	508, 635, 762, 890, 1016, 1143	2,280 to 5,830	3,080 to 7,900
5022	92	42	2 x 4	50 x 102	20, 25, 30, 35, 40, 45	508, 635, 762, 890, 1016, 1143	4,560 to 11,700	6,180 to 15,800
5023	52	24	2 x 4	50 x 102	20, 25, 30, 35, 40, 45	508, 635, 762, 890, 1016, 1143	3,980 to 10,200	5,400 to 13,800
5024	97	44	2 x 4	50 x 102	20, 25, 30, 35, 40, 45	508, 635, 762, 890, 1016, 1143	5,630 to 14,400	7,640 to 19,600
5025	104	47	4 x 7	102 x 178	30, 35, 40, 48	762, 890, 1016, 1219	7,620 to 13,600	10,300 to 18,400
5026	177	80	4 x 7	102 x 178	30, 35, 40, 48, 54	762, 890, 1016, 1219, 1372	13,600 to 27,800	18,500 to 37,700
5027	165	75	2 x 4	50 x 102	30, 35, 40	762, 890, 1016	17,200 to 23,800	23,300 to 32,200
5028	330	150	4 x 10	102 x 254	42.5, 48.5, 54.5, 60.5, 72	1080, 1232, 1384, 1537, 1829	20,500 to 39,100	27,800 to 53,000
5029	516	234	4 x 10	102 x 254	60.5, 66, 72, 84	1537, 1676, 1829, 2134	42,100 to 62,300	57,000 to 84,400
5030	486	220	4 x 7	102 x 178	48, 54, 60, 66	1219, 1372, 1524, 1676	32,000 to 46,000	43,400 to 62,400
5040	570	259	4 x 10	102 x 254	48.5, 54.5, 60.5	1537, 1676, 1829, 2134	29,100 to 45,300	39,500 to 61,400
5043	N/A	N/A	4 x 7	102 x 178	48, 54, 60, 66, 72, 84	1219, 1372, 1524, 1676, 1829, 2134	77,170 to 152,785	10,669 to 21,123
5044	N/A	N/A	4 x 10	102 x 254	60.5, 66, 72, 84	1537, 1676, 1829, 2134	98,251 to 148,228	13,584 to 20,493
5045	N/A	N/A	4 x 7	102 x 178	54, 60, 66, 72, 84	1372, 1524, 1676, 1829, 2134	99,907 to 169,785	13,813 to 23,474
5046	N/A	N/A	4 x 10	102 x 254	60.5, 66, 72, 84	1537, 1676, 1829, 2134	124,509 to 187,841	17,214 to 25,970
5047	N/A	N/A	4 x 7	102 x 178	54, 60, 66, 72, 84	1372, 1524, 1676, 1829, 2134	128,453 to 218,294	17,759 to 30,180
5048	N/A	N/A	4 x 10	102 x 254	60.5, 66, 72, 84	1537, 1676, 1829, 2134	152,460 to 230,010	21,078 to 31,800
5049	N/A	N/A	4 x 7	102 x 178	54, 60, 66, 72, 84	1372, 1524, 1676, 1829, 2134	156,997 to 266,805	21,706 to 36,887

* Braking torque is dependent on several factors; please consult the factory for specific application information.

Larger brake calipers available; please consult the factory.

Other Kobelt systems available:



Electronic, Pneumatic & Hydraulic Controls



Complete Hydraulic Systems



Ventilated Discs in Cast Iron and Bronze

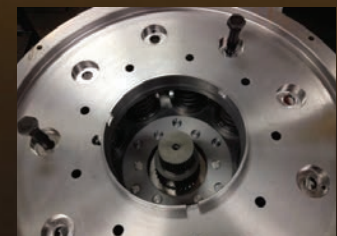

Additional Braking Solutions

KOBELT
Putting you in control.

KOBELT MANUFACTURING CO. LTD.

+1 (604) 572-3935 • Surrey, BC, Canada
sales@kobelt.com • www.kobelt.com